

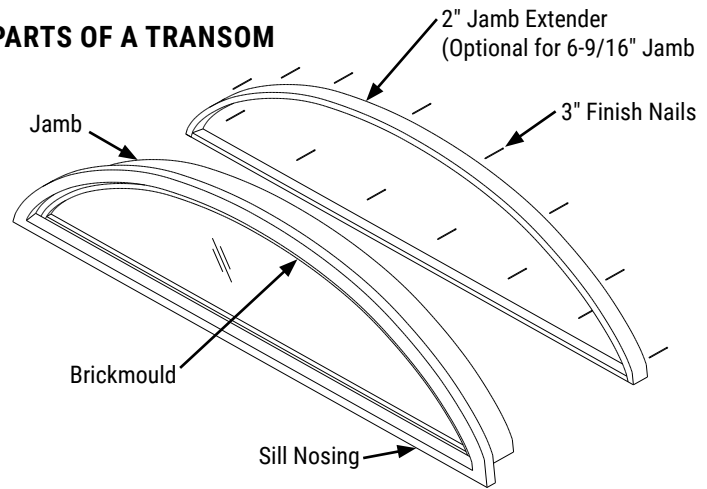
# TRANSOM Installation Instructions

Please follow the instructions carefully for proper installation. **CAUTION: Some transoms are heavy and may require two people to lift and install. Use proper lifting techniques and follow safe working practices.**

## TOOLS AND MATERIALS NEEDED:

- Tape Measure
- Pencil
- Hammer
- Carpenter Square
- Level
- Wooden Shims
- Power Drill With Phillips Drill Bit
- Saw
- Safety Glasses
- Rubber Gloves
- Caulking Gun
- Quality Clear Exterior Sealant
- Wood Screws
- Putty

## PARTS OF A TRANSOM



## BEFORE YOU BEGIN:

1. If you need to extend the width of the jambs for a thicker wall, you will need to purchase a transom jamb extender. Attach using 10d 3" galvanized finish nails at each end and 8" to 10" equally spaced.
2. Make sure that the new transom will fit properly in the frame opening. The recommended rough opening is 3/4" wider and 1/2" higher than the transom unit. Resize the opening if needed. Verify that the frame opening is level, square and plumb. Minor out of level conditions can be corrected by using shims but major misalignments need to be corrected before installation.
3. If installing a "half-round" or "elliptical" transom, you will need to install additional anchor points to secure the transom as shown in **Figure 1a** or **Figure 1b**. Installing a rectangular transom will be similar but without adding extra braces.

## INSTALLATION:

For installing a transom on a pre-hung, follow steps 1 & 2. For installing a transom only, follow steps 1 & 3.

- 1 IMPORTANT:** Before installing the transom unit into the rough opening, a pair of braces need to be installed.

Use 2x4 material or as close to the width of the wall opening as possible and fasten down. For a "half-round" transom, place both braces so that they are in a 45° angle and spaced with 1/2" clearance above the transom jamb, as shown in **Figure 1a**. For an "elliptical" transom, place both braces so that they are in a 20° angle and spaced with 1/2" clearance above the transom jamb as shown in **Figure 1b**.

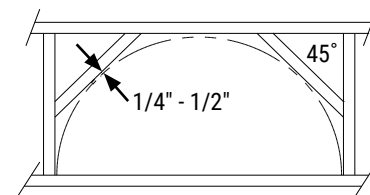


Figure 1a

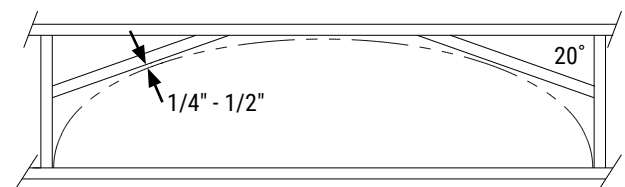
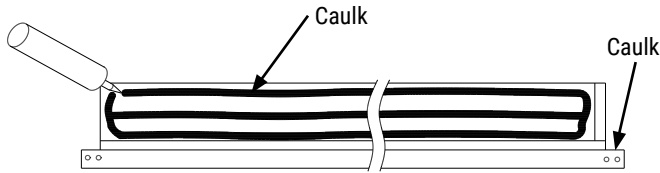


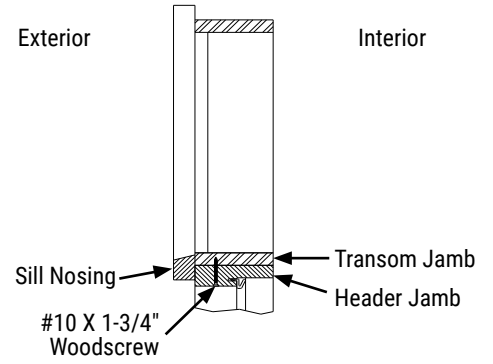
Figure 1b

**2 To install a pre-hung / transom combo:** When installing the transom with a pre-hung, also refer to pre-hung installation instruction that came with the pre-hung. Apply a generous amount of silicone exterior sealant on the bottom side of the transom jamb and on the inside of the transom brickmould, as shown in **Figure 2a**. Make sure that the transom's brickmould is flush against the outside edge of the header on the pre-hung system. Once the transom is centered, flush and plumb, fasten together with (5) #10 X 1-3/4" wood screws, as shown in **Figure 2b**.

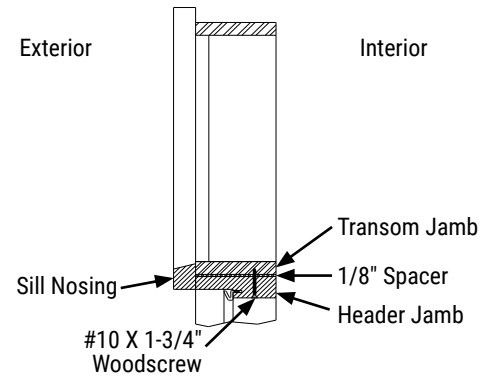


**Figure 2a**

For transom installation on an outswing door system, a 1/8" spacer will be needed in between the bottom transom jamb and the door header jamb as shown in **Figure 2c**. The spacer should run the full length of the transom. Apply the exterior grade silicone sealant in between the jamb header and the spacer.

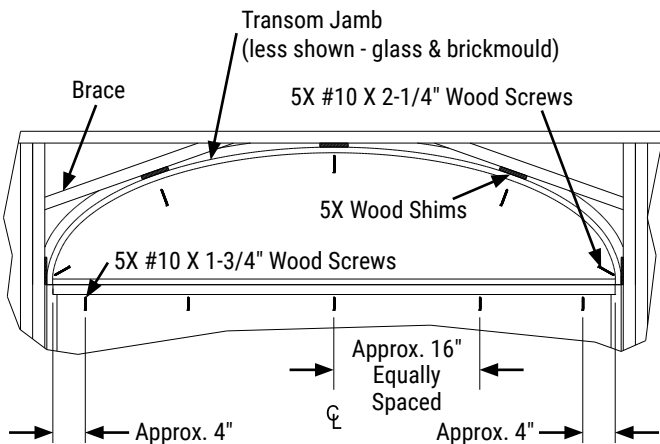


**Figure 2b**  
(Inswing System)

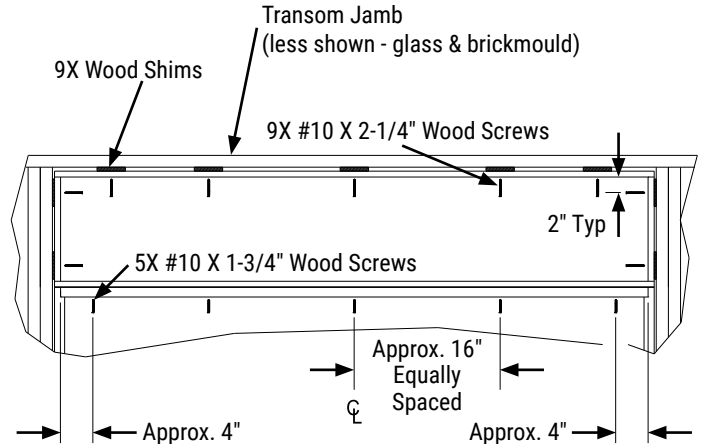


**Figure 2c**  
(Outswing System)

Insert the fasteners as shown in **Figure 2d** or **Figure 2e** depending on the configuration.

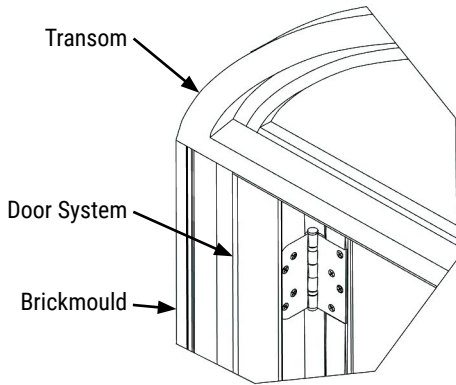


**Figure 2d**  
(Half-round or Elliptical Transom)

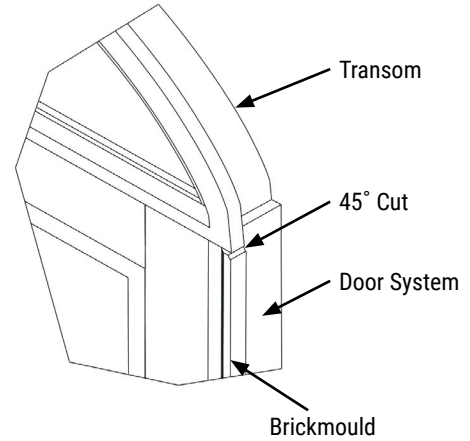


**Figure 2e**  
(Rectangular Transom)

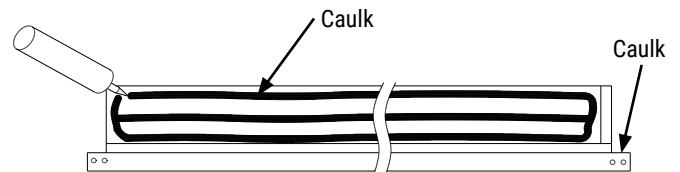
**BRICKMOULD FOR INSWING SYSTEM:** Before attaching the brickmould to the door system, you will need to cut the brickmould to the correct height. Measure from the bottom of the door sill to the underside of the transom resting on the door header jamb. This will be the length to cut the brickmould. Align the brickmould with the transom brickmould and fasten into place. Repeat this for the brickmould on the other side.



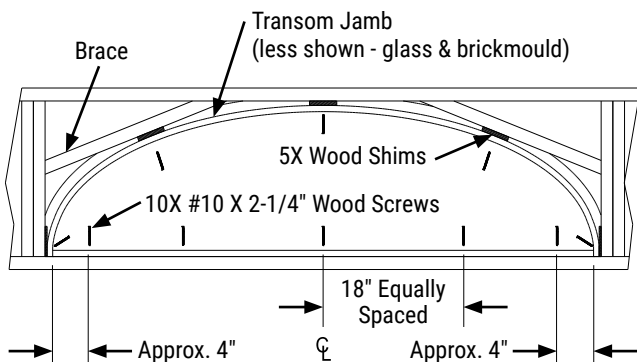
**BRICKMOULD FOR OUTSWING SYSTEM:** Before attaching the brickmould to the door system, you will need to cut the brickmould to the correct height just like for the inswing system. Put the brickmould into place with approximately 1/4" gap between the brickmould and hinges. With a pencil, mark a line from the bottom corner of the transom down at an approximate 45° angle on the brickmould, as shown below. Remove the brickmould and cut on the marked line. This will help transition both brickmoulds and will also help prevent water build up. Repeat this for the brickmould on the other side.



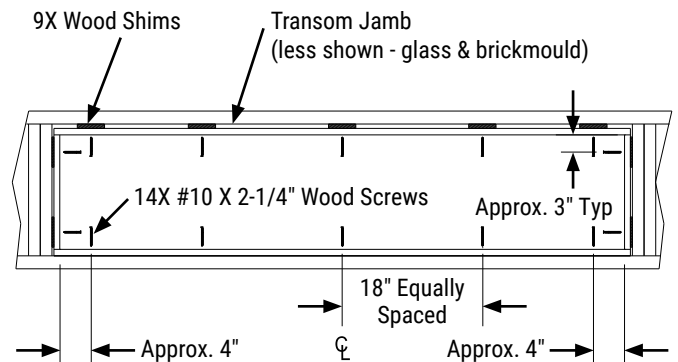
**3 To install a transom only:** Apply a generous amount of exterior grade silicone sealant on the bottom side of the transom jamb and on the inside of the transom brickmould as shown in **Figure 3a**. Once the transom is inserted and is centered, flush and plumb, insert #10 x 2-1/4" woodscrews, through the transom jamb, shim and into the braces as well as the header and sill as shown in **Figure 3b**. If this is a rectangular transom, there will be no braces. The additional anchor points will be going through the transom jamb, shims and into the trimmer (side) studs, as shown in **Figure 3c**.



**Figure 3a**



**Figure 3b**



**Figure 3c**